



Better People Better Business

www.linuxmagnetics.com





LEADERS IN
MANUFACTURING OF
MAGNETIC
&
VIBRATING
PRODUCTS.



ABOUT US

Linux Magnetics Leader in manufacturing of magnetic products & Vibrating Screening Equipments. Since its inception, **Linux Magnetics** has taken strides in manufacturing of permanent magnetic equipment, electromagnetic equipments and all types of magnetic & vibro equipments . **Linux Magnetics** is an ISO 9001: 2015 Certified Company. The founder of the company Mr. Pritesh Patel has tons of experience since last 20 years in this industry which results in the functionality, product development and services of our company. Our products are of top notch quality and we always look forward to meet customer requirement.

We are capable of manufacturing various magnetic equipments & vibrating equipments based on the requirement of the clients. We are having a group of skilled workers working for the timely accomplishment of projects undertaken without compromising on the quality. Our magnetic equipments have been successfully used in various industries.

Linux Magnetics has been able to develop an impeccable reputation in Gujarat owing to its policy of manufacturing under strictest international quality norms to give products that offer trouble free and user friendly operations and at the same time are economical and highly productive.

Product Range

- Magnets
- Magnetic Equipments
- Electro Magnetic Equipments
- Vibrating Equipments

Infrastructure

Established in the industrial hub of Ahmedabad, the company stands equipped with the most refined men and machines to deliver the best of technology and performance in the products. Our state of the art technology and machinery with highly competent manpower have helped us to maintain top notch quality at all levels.

Our products are designed, engineered, and tested with high precision in-house, under the supervision of highly competent people. Not just machinery parts, we are also open to provide you with total technical help and assistance to provide you with complete technical know-how for incorporating the products.

Our Technology

In order to serve the increased market demand for magnetic and vibratory equipments, Linux Magnetic has created a portfolio of technologies aimed at generating 100% yield and 100% e.e. TM concepts. We approach challenges in an integrated manner, with combination of proprietary technologies and in house engineering expertise.

For you, as our customer, this means that whatever the challenge, Linux Magnetic can provide you with most economic and best solution.

BEST QUALITY PRODUCTS

Linux Magnetic prides itself on the quality of its products, which gives the company an important competitive edge. The company's offerings comply with the strict regulatory requirements of our clients.

TOP QUALITY SERVICE

At Linux Magnetic we know that in today's complex and sensitive Industry, total reliability is of the essence. That's why we strive to ensure our customers peace of mind in every way. Specializing in Tailor-made products and complete turnkey offering, we offer customers a close, long- term partnership, and a fast, full response to every request. Propelled by team of experts and qualified engineers, the company offers wide range of high tech Magnetic Separators and Vibratory Equipments.

STATE-OF-THE-ART TECHNOLOGY

Linux Magnetic modern R&D facilities are equipped with advanced Instrumentation, equipments. With the team and equipments in place we are constantly offering new and unique technologies - for customers who seek diverse line of high-tech Magnetic Separators I Vibrating Equipments.

Our Computer Aided Design (CAD) team is equipped with the most advanced technology to design machinery equipment. Each prototype of machine is designed keeping its work efficiency in mind. We are continuously upgrading ourselves with the latest developments in the field of machines and their utility.



Value Added Services

Having many successful satisfied customers, we are proud of our reputation as a leading manufacturer of magnetic and vibratory equipments in the industry.

Our unmatched commitment to customer service, a deep understanding of our customers needs and the launch of innovative products remain unparalleled in magnetic and vibratory equipments industry.

We have an experienced and skilled professional team who is always available to our customers for fast and competent response to every need. We are the only magnetic & vibrating equipment manufacturer to offer these unique services.

We are committed to provide highly reliable and long term customer service. We offer various customized services, which are mentioned below:

- 24x7 round-the-clock service.
- Dedicated and decentralized after-sales service.
- Spare parts and customer support.
- Annual maintenance contracts.
- Customer training.

We add **MORE VALUE** to your business.

We serve our customers **ON TIME, EVERY TIME**.

With our complete and customized solutions, **OUR CUSTOMERS** have **MORE TIME** to look after their **CORE BUSINESS**.

Our Business

MANAGEMENT AND FAST CUSTOMER - FOCUSED RESPONSE

Linux Magnetic is rapidly growing enterprise. Coupling advanced R&D capability with experience and business know how has helped us respond favorable to all challenges. The company's basic offering comprises of quality machinery that comply with our customer's exact needs.

We always follow an innovative and well charted approach to problem solving, a combination of creativity, application timeliness. We believe in taking the right initiative and responding to new opportunities. Above all it is our experience helps us to focus on advancement - for the benefit of our present and future customers. Your submitted machinery needs are sent to our engineering division to identify technical and output issues to determine the appropriate fit with capabilities. The approved project is assigned to our dedicated production engineers who are committed to meet your requirement in quality and costs.

LINUX MAGNETIC ONLINE CONTACTS FOR INQUIRIES

A Standard practice is to keep clear and open communications with our customers for 100% satisfaction. Even after project completion we remain accessible to you. We offer an easy-to-fill-out form at our offices as well as our website. Please visit us at www.excelmagnetics.com to submit your queries and inquires — we promise you a quick response.

Magnetic Equipments Index

Sr.No.	Product	Page No.
1)	Mechanical Vibratory Feeder	9
2)	Magnetic Rod	10
3)	Rectangular Vibrating Screen	11
4)	Drawer Magnet	12
5)	Hump Magnet	13
6)	Pipe Line Magnetic Separator	14
7)	Bullet Magnet	15
8)	Over Band Magnetic Separator	16
9)	Concentrator Magnetic Separator	17
10)	Magnetic Pulley	18
11)	Suspension Magnet	19
12)	Inline Separator	20

Magnetic Equipments Index

Sr.No.	Product	Page No.
13)	Drum Magnetic Separator	21
14)	Magnetic D-Stoner	22
15)	Magnetic Roll Separator	23
16)	Plate Magnet	24
17)	Eddy Current Magnetic Separator	25
18)	Lifter Magnet	26
19)	Circular Vibrating Screen	27
20)	Wet Drum Magnetic Separator	28
21)	Funnel Magnet	29
22)	Electro Magnetic Vibro Feeder	30
23)	Grill Magnet	31

Our Production Site

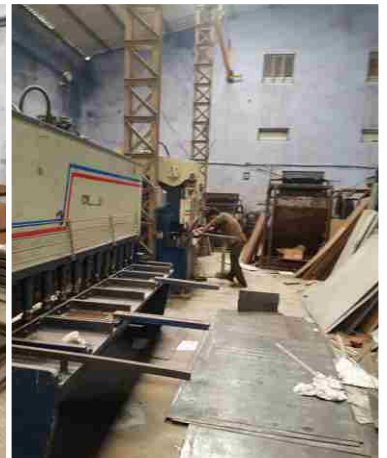



Mechanical Vibratory Feeder

Mechanical Vibrating feeders with inertial drive are designed for transport and feeding of loose, granular materials in technological and storage transport. Installed under outlets of containers Operative handling of the feeder is limited to setting the required capacity, which is performed by changing the location of unbalanced masses at the ends of electro-vibrator shafts, periodical inspection of the condition of connections and maintenance of drives in accordance with the instruction manual.

Mechanical Feeder with unbalance motor drives is economical conveying means for all bulk materials. Compared with other conveying means vibratory feeders have low energy consumption. The vibration is achieved by the eccentric movement of the out of unbalanced weights mounted on each side of motor, twin motor vibrator drives arranged for counter-rotation, provide linear vibratory action, which conveys the product across the vibrating surface. The internal part of the feeder's trough can be covered with e.g. plastic, rubber or wear lining. An advantage of the used inertial drives is the ability of stepless adjustment of the capacity during standstill. It is possible to smoothly adjust the transport rate during operation in a specified scope with the use of a rate converter. Technical parameters are presented in the attached table. Upon request of the Customer, all elements in contact with the fed material can be performed from stainless steel or other materials.

Advantages:– works well during continuous operation – act as sealing elements of the container – dustproof manufacturing process – equipped with extracting pipes

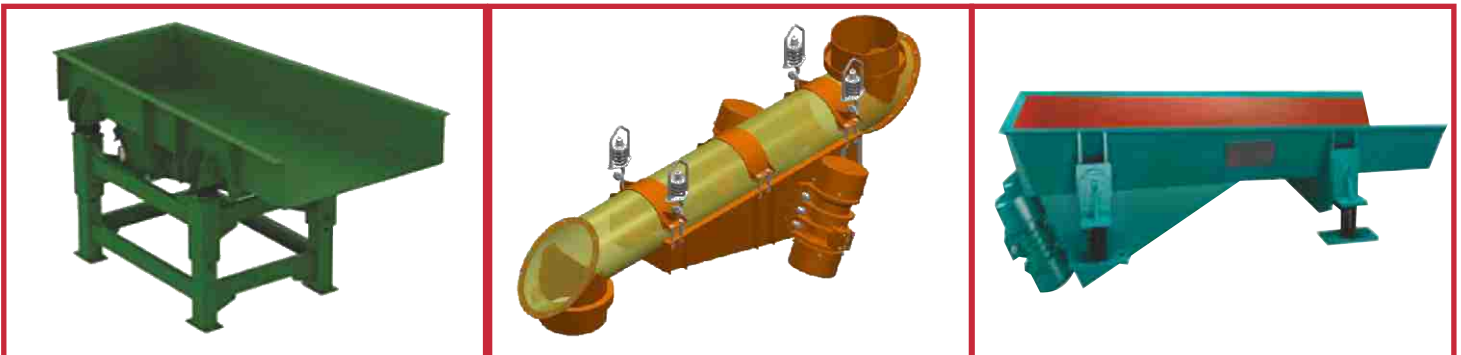



Magnetic Rod

Rare Earth Rod Magnets are extremely efficient at removing fine iron contamination from free flowing products such as ceramics slurry sugar, grain, tea, flour, granulate and any other types of powder with a low moisture content.

This item can be supplied with blank, tapped or studded ends for ease of installation. Rods are 25.4mm (1") in diameter, 32 mm diameter, 40 mm diameter and 50 mm diameter.

Rods are particularly useful for those engineers who wish to build their own separator units or have severe room restrictions and are not able to accommodate a conventional unit.

This product contact parts are manufactured using 304 and 316 grade stainless steel



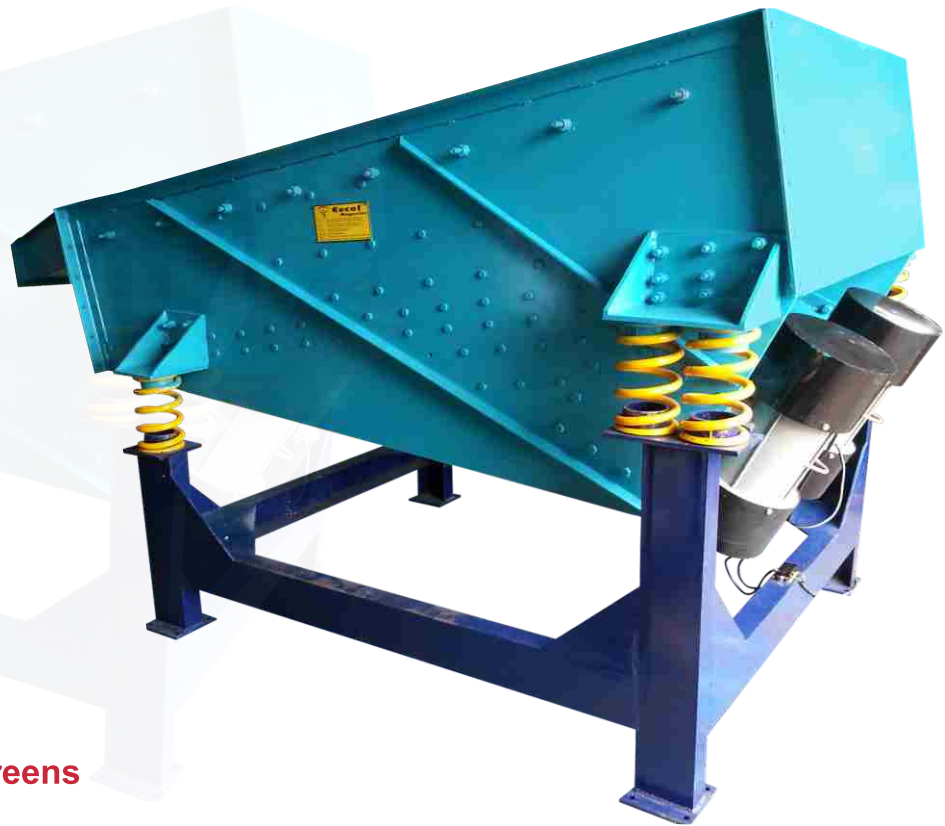

Rectangular Vibrating Screens

Rectangular Vibrating Screens is available in single double and multi stage screen we made for heavy industrial supply For any vibrating screener, screen design will be a key factor in unit performance and maintenance. Screen cloth that is highly pre-tensioned across a frame and securely bonded provides the best screening surface with the longest life. Cleaning kits incorporated into the screen design provide dynamic anti-blinding action when needed. Additionally, designs that enable screen changes without tools minimize maintenance costs and downtime.

Vibrating screens play an important role in stone ,ceramic ,glass, plastic, minerals salt etc. industries manufacturing operations. Careful analysis of all factors before ordering will result in smooth field startups and optimal production performance.

Rectangular Vibrating Screen have very high frequency vibrations which can screen upto 300 mess screening material. Which are operated by unbalanced vibro motor & center essential shaft.

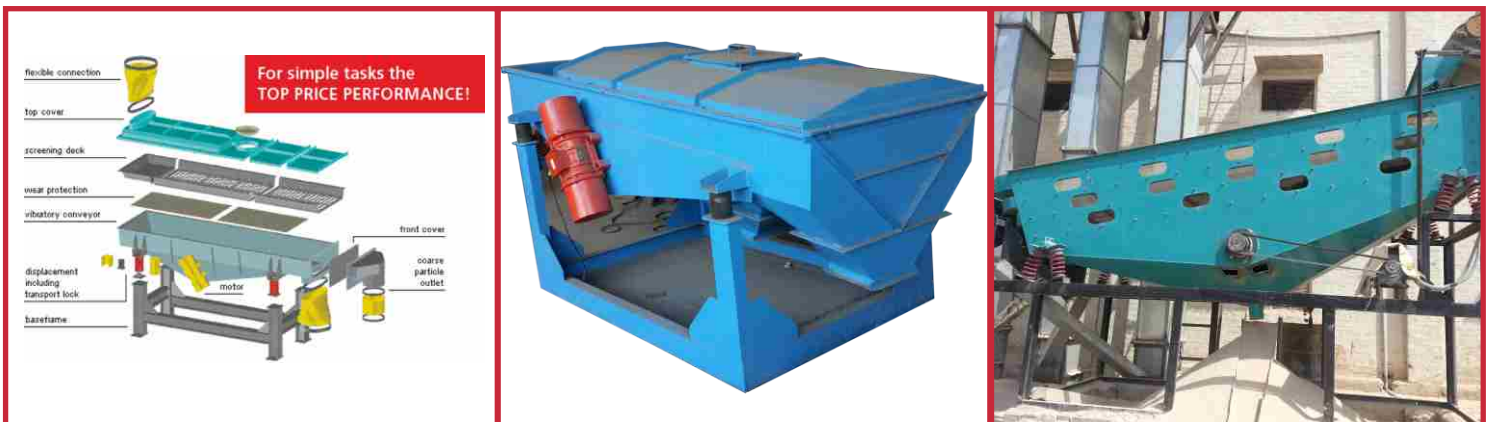



Drawer Magnet

Multi Stage Open Drawer Magnets which are available in different styles to suit specific application needs. Drawer Magnets consist of rows of round magnetic tubes that are assembled into drawers. The tubes of the drawer magnets are aligned on alternating centers from the row directly above or below it. The powerful magnets at the neck of the molding machine stops the flow of the tramp material directly into the machine parts. Our drawer magnets are very essential engineering products which are used for protecting injection molding machines, molds and dies.

Powder drawer Magnets provide excellent equipment and product protection of medium and fine ferrous contaminants in dry, free flowing products under gravity flow. Multiple staggered rows provide maximum contact area for product flow. As product flows through the stainless steel housing, it cascades over the staggered rows of magnetic tubes.

Drawer Magnets should be cleaned periodically for the most efficient performance. To clean the magnetic tubes, release the latch assembly and open the door. Remove the grate assemblies one at a time. Remove the tramp metal by hand. Use extreme caution and wear gloves during the process. Rare earth magnets are extremely powerful and tramp metal is very difficult to remove by hand.

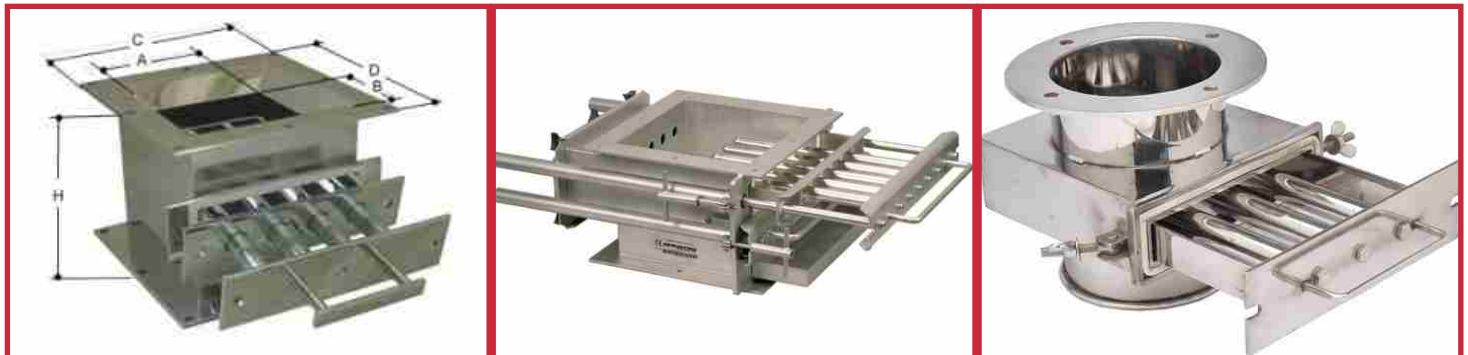



Hump Magnet

Hump Magnets generally consist of two Plate Magnets mounted in an offset housing and are installed in vertical spouts. As product enters the housing it impacts directly on the face of the first Plate Magnet, travels through the offset angle of the housing and impacts directly on the face of the second Plate Magnet. Hump magnet is a unique permanent magnetic equipment to remove tramp iron pieces from gravity flow or pneumatically conveyed mixtures, the surest way to protect your costly machinery from damages. A must for cattle feed fertilizers food processing, salt in grain handling plants.

Made from high coercivity permanent magnets. Very powerful magnetic plates hinged on sturdy, M, S Housing arrest all the ferrous particles from the material and prevent damage to the machinery. The plates can be easily swung open and cleaned.

Constructed made of heavy M. S. A Hump Magnets are made totally dust tight enclosure and easy to clean plate of Hump, in a Hump Magnet made two or multi stage are available.

This provides excellent separation results for high volume, poor flowing, or abrasive materials.





Pipe Line Magnetic Separator

Magnetic Liquid Filters are designed to remove micron sized ferrous and para-magnetic contamination from various types of liquids. A matrix of Easy Clean rods containing high intensity rare earth neodymium iron boron magnets are housed within a stainless steel vessel.

The magnetic configuration ensures maximum exposure of contamination to the high intensity rods without impeding liquid flow.

Filters are available in two versions, single wall and double wall Jacketed. Jacketed filters are used in heated pipeline applications where temperature is critical to the product viscosity, for example, chocolate, syrups, lams and sauces. Both these versions are tested and certified to operate at pressures up to 12 bar as standard, designs capable of working at 48 bar are available on request.





Bullet Magnet

Bullet magnetic separator is designed for installation in pipelines or ducted systems, to trap the ferrous particles from the powder, grain material flows over the magnetic bullet. Open the door to remove the ferrous particles on the surface of the magnetic core.

Magnetic Bullets are typically installed into pipelines and gravity feed chutes. Ferrite or neodymium magnets are used, depending on the magnetic strength required. These magnets are super cost efficient and are ideal for extracting iron particles, nuts, bolts and other ferrous contaminants.

Centre flow magnets are generally used where flowing material characteristics is sticky, not free flowing material. It is easy cleaning type of system having conical magnet fitted on hinged door. It can withstand high pressure and flow. The conical magnet also acts as deflector which helps in spreading flow material thereby improving separation efficiency of the system.



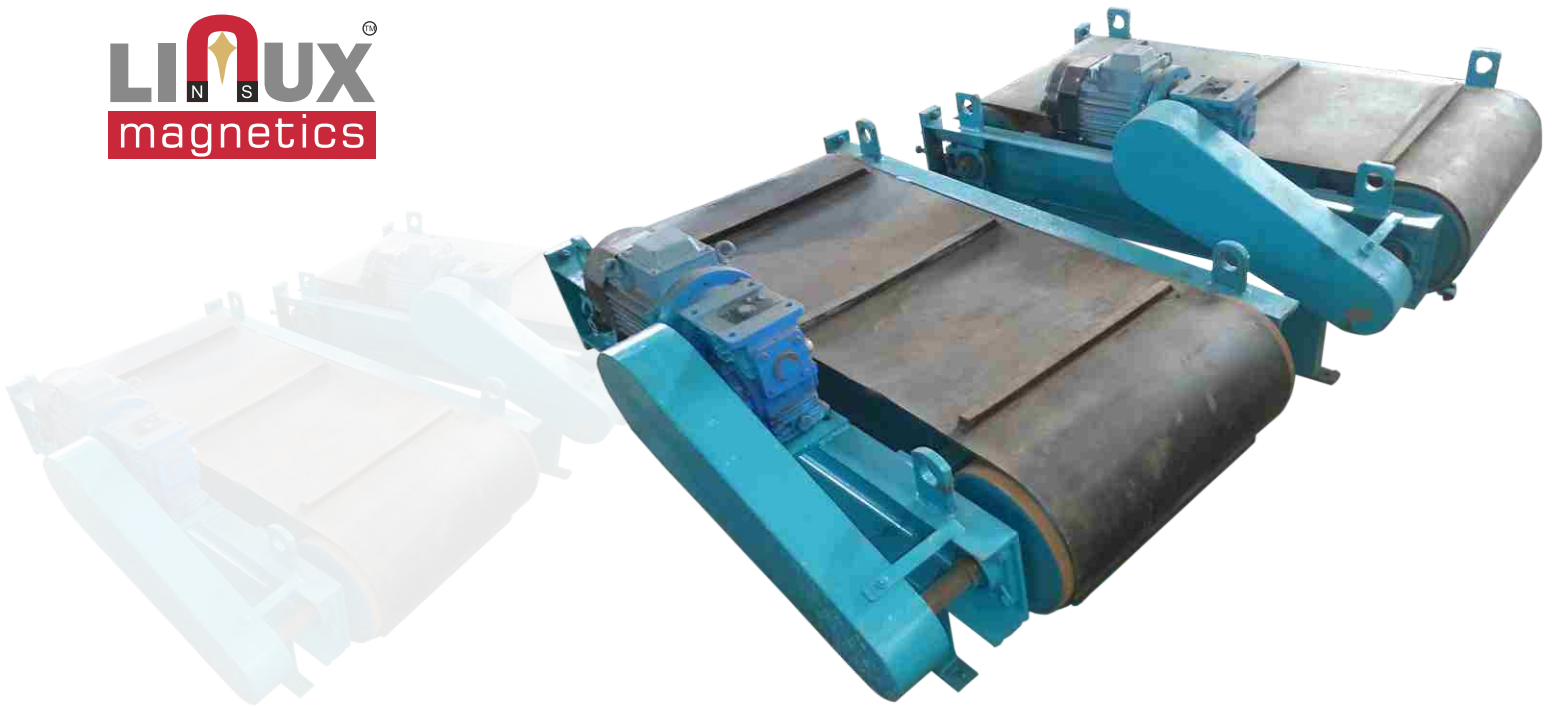

Over Band Magnetic Separator

Over Band Magnetic Separators are designed to eliminate tramp metal from the product carried by belt, Used in Recycling, quarrying and heavy industries.

Positioned above flat or trough type conveyors to continuously removed tramp iron and other ferrous contamination from bulk items. Large permanent magnetic packs generate deep penetrating magnetic flux fields.

Rubber belt is driven around two rollers with the magnetic pack positioned in the centre. Other separators used over conveyor belts include: conveyor head rollers, strip magnets, hinged strip magnets, deep field plate magnets.

The Magnet is made of High Intensity Strontium Ferrite Magnets and Rare Earth magnet are guaranteed for the Magnetic Power through out the life of installation. A Non - Magnetic Stainless steel Plate is provided to cover the poles of Magnet. There is no need for any electrical supply or maintenance.



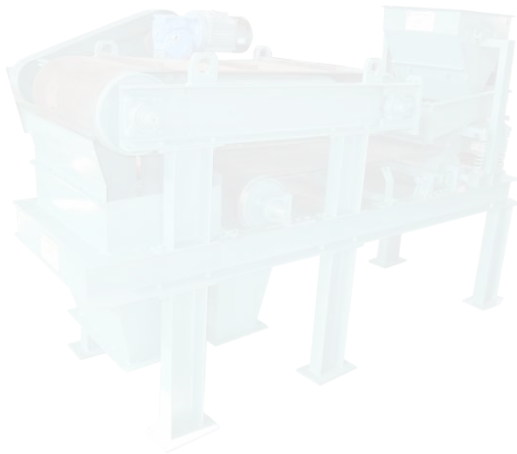

Concentrator Magnetic Separator

We are counted amid the reputed Permanent Concentrator Magnetic Separator Suppliers. Permanent Magnetic Concentrator Separator is widely used for upgrading or concentrating material containing a very high percentage of magnetic or where magnetic/mechanical agitation is required for the separation of many difficult materials. Concentrator Magnetic Separator or Permanent Magnetic Separator is ideal for the upgrading of sponge iron/cast iron borings, steel/brass/aluminium turnings, chips and for mineral beneficiation applications such as the purification of dry ceramic and refractory materials, reclamation of abrasive grains, removal of iron contamination from chemical powders and grains and for many other such applications requiring maximum separation with a minimum product loss. The Concentrator Magnetic Separators can be purchased in various technical specifications from us.

This special equipment has some versatile usage for concentration of Ferrite & Magnetic material, up gradation of Sponge Iron purity, separating ferrous contamination from non – ferrous materials like Aluminum, Brass, Bronze, and Copper, coal etc. The ceramic & refractories industries also have the widest usage for purification. Chemical industries find its applications for removal of iron from chemical powder & grains

Basic Principle

The machine works on the induced magnetism principle whereby the separations with segregation become possible. This ensures the recovery of product in terms of concentration and with high degree of purity. The sponge iron industries in particular where the losses of valuable magnetic material with the non –magnetic portion takes place can easily be avoided and thus the sponge iron purity with 99% can be achieved.

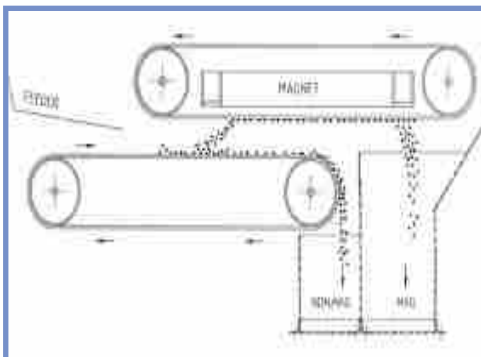

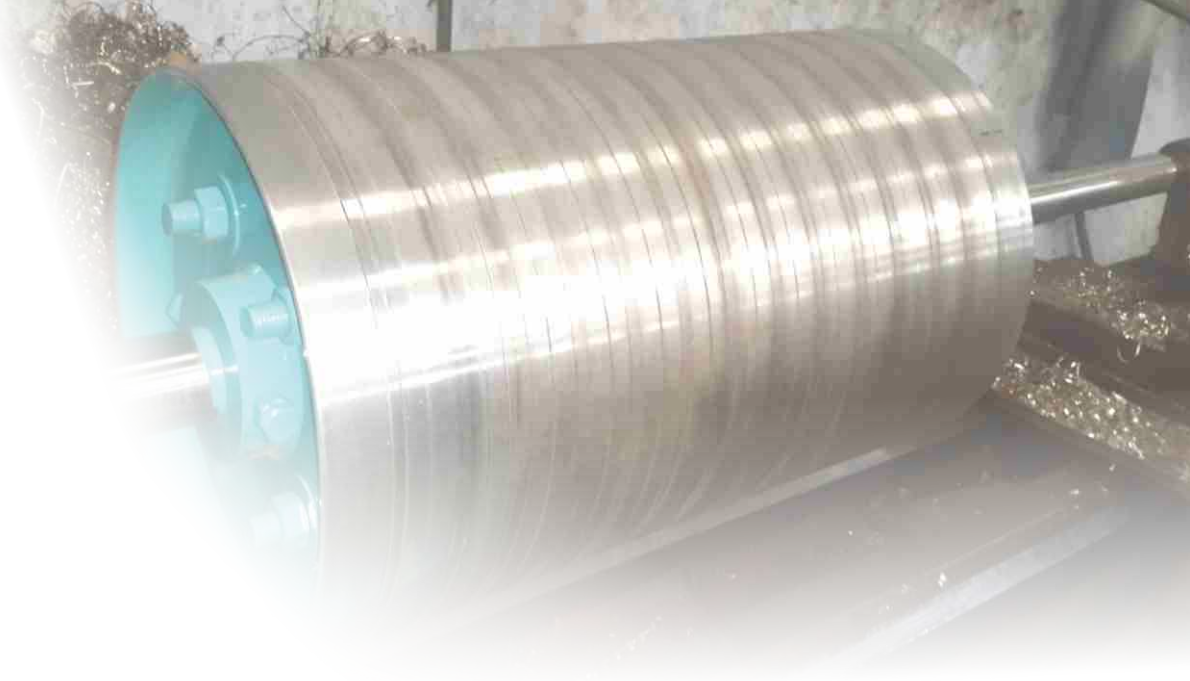

Magnetic Pulley

The magnetic head pulley replaces the drive pulley at the end of conveyor belts. In view of the wide variety of conveyor belt types, the magnetic pulley are supplied made to measure and ready for installation. As the figure clearly show, the magnetic head roller extracts the iron particles from the material flow and carries them to the underside of the belt where they are removed and collected.

The version with permanent magnets are fitted with powerful high intensity Nd - Feb Rare Earth Magnets and An-Isotropic Hard ferrite Magnets and operate without the need for power supplies. The magnet system is available in two types: with Longitudinal polar field distribution for use with low levels of iron contamination and thin material layers, and with lateral polar field distribution for greater material thickness and larger iron particles.

Finally as the belt leaves the magnetic pulley, the magnetism dissipates and the unwanted contamination falls from under the belt into a separate receptacle. this kind of magnetic pulley are use in various applications like cement plant, crushing and minerals industries, steel and glass plant etc.



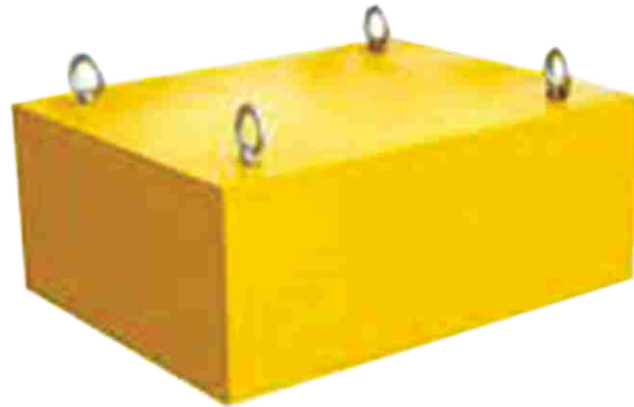

Suspension Magnet

This unit simply suspends above the conveyor belt or the head pulley and lifts tramp metal from the product burden as it passes through the powerful magnetic field. Four eyebolts are provided for suspension (suspension chain not included). Cleaning is achieved by manually removing the collected tramp metal from the face of the magnet EASY CLEAN options are available to simplify cleaning. Available in permanent and electromagnetic designs.

Suspension Type Magnets use is recommended for low contamination products. Over band type Magnetic Separator is recommended for this type of application. The capacity of suspended magnet is 20 inch coverage area.

The principal applications are for processing of bulk products such as Culletts, Glass, Coffee, Ceramics, Minerals, Coal, Sugar and Crushing Plants, etc.,

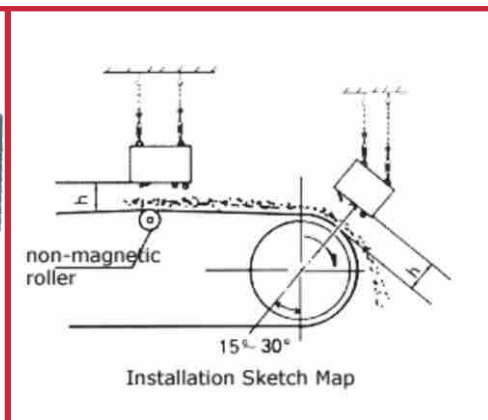



Inline Separator

Persistently marching in today's competitive market, our company is recognized as one of the well established manufacturers and exporters of Inline Separator. These separators find wide usage in various industries like pharmaceuticals, plastic manufacturing, minerals, glass manufacturing and food industry. The offered range of Inline Separator is well accepted in the market for its distinctive features like easy installation, low maintenance and robust construction. Our separators can be availed by our customers in different technical specifications.

Further Details:

The drum consists of high coercivity modern anisotropic and permanent magnets. The strong and durable fabrication leads to the longevity of the investments made by the customers.

Our range is renowned and well liked in industries such as mining, material processing, domestic waste recycling plants and ceramic handling. Our range of inline drum type magnetic separators has various other features, such as

- Automatic separation of impurities from the iron.
- Designed for complete protection from dust and pollution.
- Requires very little maintenance.
- Available in various configurations and sizes.



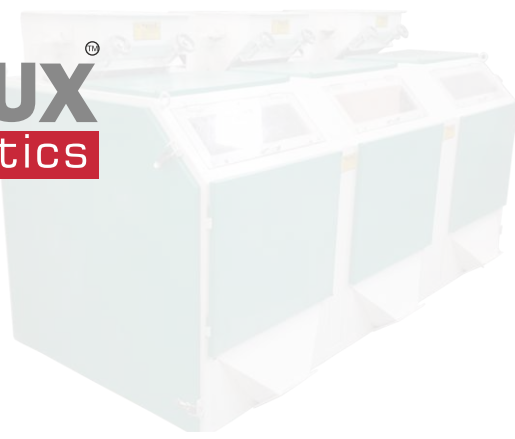

Drum Magnetic Separator

Magnetic Drum Separator

Drum Type Magnetic Separators are used for Automatic separation of Magnetic Particles from Raw Material. Drum Type Magnetic Separators are available In many designs. Here available in Single, Double and Multi Stage Drum Separator

Single Drum Magnetic Separator

Single Drum Type Magnetic Separators are available for in medium and high intensity magnet. The material passes through the magnet drum type Machine respectively. These are widely used for separation of iron contamination from Minerals, Chemicals, Refractories and many other products. High power permanent Magnetic Plate is provided at material outlet. Modern An-Isotropic Permanent Magnets are used having highest magnetic strength. Machines are available with vibrating material inlet Hopper and totally enclosed design to avoid dusting and pollution

Double Drum Magnetic Separators

Double Drum Type Magnetic Separators are available for highest purity. The material passes through the magnet twice time drum separator and High power permanent Magnetic Plate is provided at material outlet. They are comprised of a stationary permanent magnet, either standard Ferrite Magnets or High Power Rare Earth Magnets enclosed in a non-magnetic stainless-steel drum. Product flow is diverted so that it falls onto the top and flows across the surface of the drum. Ferrous matter contained in the product flow is drawn to the drum's surface by the powerful magnet housed inside.

Multi Stage Drum Separators

Triple & Multi Drum Type Magnetic Separators are available for highest purity.

The Permanent Drum Separators are available in standard drum diameters of 300mm to 1200mm width range from 300 mm to 2500 mm. Other sizes can be made as special to your requirement. The larger the diameter and width of the drum the greater is the volume of material which can be hand land.

These are generally manufactured as custom made where the separation is required to the highest purity of material. The material to be made free of iron particles is passed over the first magnetic drum and again in continuous process fed to the second and similarly to the third. This process ensures the purity of the material of the highest order.





Magnetic De-Stoner

Rare Earth Rod Magnets are extremely efficient at removing fine iron contamination from free flowing products such as ceramics slurry sugar, grain, tea, flour, granulate and any other types of powder with a low moisture content.

This item can be supplied with blank, tapped or studded ends for ease of installation. Rods are 25.4mm (1") in diameter, 32 mm diameter, 40 mm diameter and 50 mm diameter.

Rods are particularly useful for those engineers who wish to build their own separator units or have severe room restrictions and are not able to accommodate a conventional unit.

This product contact parts are manufactured using 304 and 316 grade stainless steel

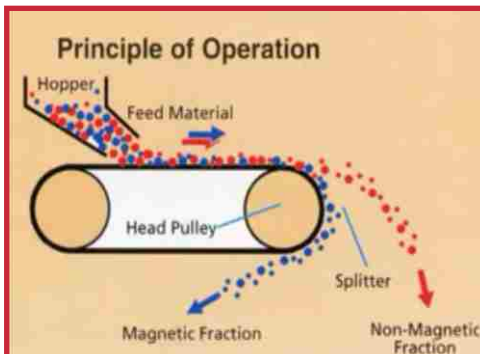



Magnetic Roll Separator

Rare Earth Rod Magnets are extremely efficient at removing fine iron contamination from free flowing products such as ceramics slurry sugar, grain, tea, flour, granulate and any other types of powder with a low moisture content.

This item can be supplied with blank, tapped or studded ends for ease of installation. Rods are 25.4mm (1") in diameter, 32 mm diameter, 40 mm diameter and 50 mm diameter.

Rods are particularly useful for those engineers who wish to build their own separator units or have severe room restrictions and are not able to accommodate a conventional unit.

This product contact parts are manufactured using 304 and 316 grade stainless steel





Plate Magnet

Plate Magnets are designed for use in chutes and suspension over conveyed product. Installed on the bottom side of a chute, a Plate Magnet will provide maximum protection as product travels through the powerful magnetic circuit. The magnetic field protects from the face of the Plate Magnet reaching into the product stream and pulling the ferrous contaminants to the magnet face. The magnetic field on a Plate Magnet is strongest at the surface and gets weaker the further you move away.

Permanent Magnetic Plates are designed in various sizes & strengths to meet with specific operation & plant conditions. Magnetic Plates are widely used for removing Tramp iron such as Bolts, Nuts, Bits of Wire, Nails and other casual containmination from free flowing materials to protect against occasional damage to the plant caused by bits of iron.

Plate Magnets can ideally be used to remove tramp iron from the moving material carried in chutes ducts, spouts or on conveyor belts, screens and feed trays. Whether the material is plastic or paper pulp, food or fertilizer, Oil seeds or gains the result is sure protection of processing machinery and iron free final products





Eddy Current Magnetic Separator

The Eddy Current Separator (ECS) is an advanced metal sorting unit that is capable of separating non-ferrous metals such as aluminium and copper from dry recyclables. Non-ferrous separators are very common in the fast growing market of beverage can sorting, where they can provide an accurate separation of aluminium cans from waste streams. Depending on the application, there are four rotor options available from Master Magnets. For more information on each rotor specification, please click on the models tab above.

Operating Principles

An Eddy Current Separator consists of a short belt conveyor that has its drive located at the return end and a high speed magnetic rotor system installed at the discharge end. The magnetic rotor, which is positioned within a separately rotating non-metallic drum, revolves at around 3000 revolutions per minute during operation whilst the outer drum cover rotates at the speed of the Eddy Currents' belt conveyor.

As the rotor spins at these high speeds, an electric current is induced into conducting metals. The induced electric current produces a magnetic field, which opposes the field created by the rotor, repelling the conducting metals over a pre-positioned splitter plate. The remaining materials such as plastics, glass and other dry recyclables will simply free-fall over the rotor, separating them from the repelled metals.

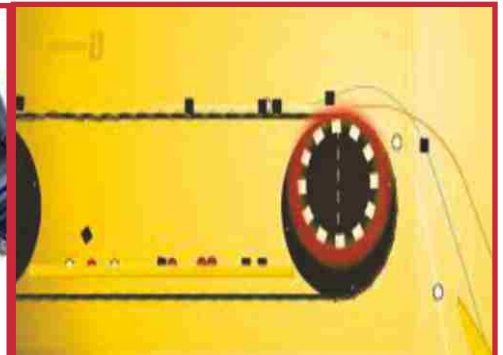



Lifter Magnet

Excel compact Rare - earth Permanent lift magnetic, turned On and OFF manually by lever provide smooth operation for hundreds of lifting and positioning application. These magnetic are ideally suited for in plant handling, loading /unloading of machine tools, in machines shop, engineering companies, steel plants, etc. No electricity needed, no batteries to or replace dont threaten safety Guarantees continuous, Complete magnetic power, even after years of intensive use. Available with V face pipes rounds and other hard to handle shapes. Available in 100 to 5000 kg rated lifting capacities with 33% safety factors that means magnetic are testing over 3.5 times the rated load.

Circular Electro Lifter Magnets are designed to eliminate scrap iron tramp metal from the raw material, Used in Recycling, quarrying and heavy industries.

Offered in fabricated cases, with coils and terminals sealed and protected to ensure watertight construction and low maintenance costs. Sizes range from 530mm to 1525mm in diameter to suit all crane sizes and models. Magnets are designed for cool operation and minimum reduction In lift capacity, to provide maximum lift performance throughout the working day.

Cases are constructed of high-permeability, low carbon steel for minimum magnetic leakage and maximum lifting efficiency. Bottom plates are heavy manganese steel. Class H insulation is used throughout the magnets for extended life.



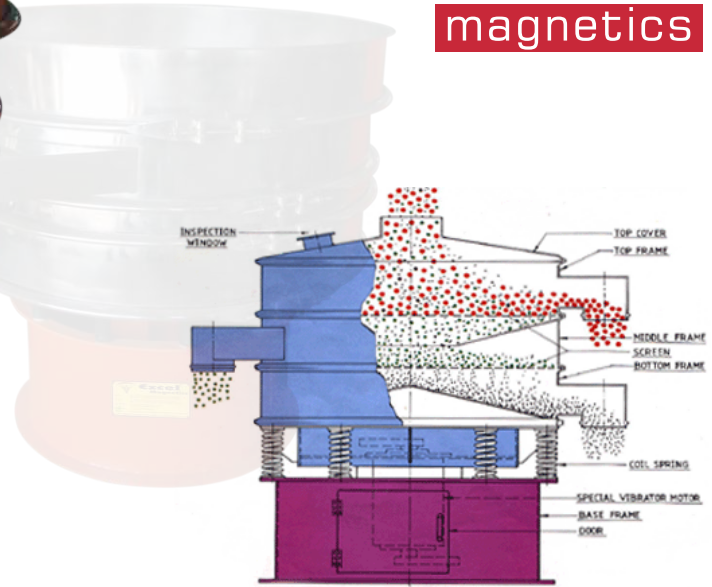

Circular Vibrating Screens

Circular Vibrating Screen has come out with a most advance design of screens for grading of fine, wet and difficult to screen materials. The screens works on the principle of gyratory motion. The unique features of this type of sieve is its high capacity using minimum space and less power.

The screen has specially designed multi-directional vibration system which prevents blinding of sieves. The material to be screened is fed from the top and collected simultaneously from outlets of different decks. These screens can handle wide range of materials such as heavy, light, dry, wet coarse or fine. The company manufactures various sizes to suit individual requirement in M S and S S construction.

Vibratory motion is the most effective method for screening. It causes 100% rotary motion and causes dispersion stirring & stratification of material to be sifted. Feed material constantly flows in Horizontal motion along a loop pattern on Vibro screen surface."EXCEL" Vibro screen provides optimum screening & assures maximum feed-rate & efficiency





Wet Drum Magnetic Separator

The Wet Drum Magnetic Separator is used to remove very fine magnetisable components from low concentration, low-viscosity liquids. The wet separator is intended for use in the metal processing industry and for the treatment of preconcentrates extracted from the high gradient magnetic filter.

The liquid flows through a semicircular separating chamber beneath a stainless steel drum to which the magnetisable particles are attracted. The strong, high-gradient magnetic field is created by a cylinder consisting of permanent magnetic discs positioned within the drum. These special permanent magnets generate particularly high field gradients which are necessary for successful separation, as is the need with all magnetic separators. Wet drum magnets have high magnetic recovery and discharge. The feed slurries recover the magnetic. It is available in single or multiple drum applications. The drum is made from thick stainless steel for long service life. Wet drum separators are available in different configuration like single drum, double drum and multiple drum.

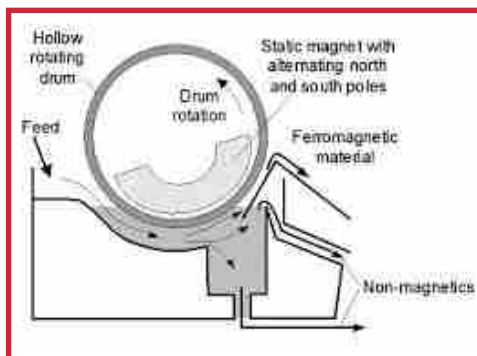



Funnel Magnet

We have developed optimum quality funnel magnets that are extensively used for free flowing material. The iron impurities can harm the lined machineries. It is used to get pure and contaminants free material for the good quality of product.

It also helps to eliminate harmful effect of ferrous bits and pieces to precious machineries. Funnel magnets can be locate in production line and offer proper removal of contaminants. In several industrial applications like ceramics, raw material must be very smooth and free from all kinds of impurities. It is also used for glaze fabrication.





Electro Magnetic Vibro Feeder

With almost 1 decade of market expertise, we are manufacturing and supplying Electromagnetic Vibratory Feeders that are widely used for controlling flow of materials. The offered feeders are manufactured by making use of the best quality components and cutting edge techniques in accordance with the international industry standards under the observation of our experts. Additionally, our patrons can purchase these Electromagnetic Vibratory Feeders from us at the most affordable rates within the promised time span.

Products Features:

- Rigid structure
- Optimum performance
- Corrosion resistance
- Excellent durability

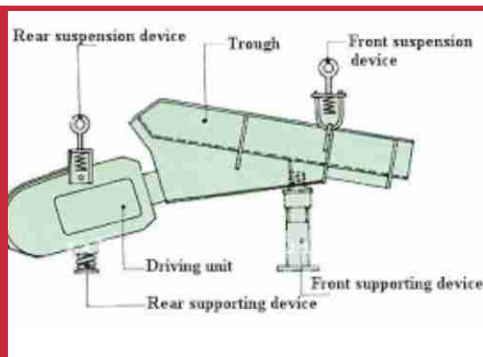



Grill Magnet

Grill Magnets are important magnetic separators, used for separating tramp iron or ferrous contaminants from free flowing granular materials. Our grill magnet are made of rare earth magnets or ceramic magnets. The magnetic grills are aligned in certain angles that attracts the contaminants. Available in various shapes and sizes, our grill magnets have wide applicability in various industries like chemical industries, food processing industries, mining and mineral industries plastic and ceramic industries etc.

Grill Magnets offer excellent protection from metal contamination. As product flows over the magnetic tubes, captured metal contaminants are pushed to the underside of the tube where they are now out of contact with the product flow preventing was hoff back in to the clean material.



Our Valued Clients

Our Valued Clients

Other Products Range



Vibrating Motor



Open Funnel Magnet



Coolant Magnet



Magnetic Concentrator Separator



Gauss Metter

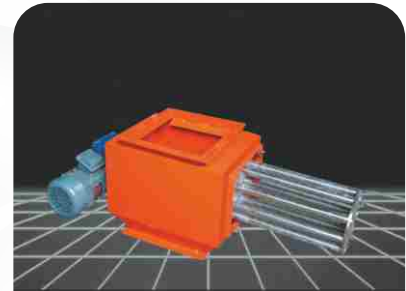

Rotary Type Magnet



Motorised Vibro Feeder



Rectangle Vibro Screen



Metal Detactor



Bin Active Vibro



Magnetic Floor Sweeper



High Intensity Slurry Sep.



MAGNETIC EQUIPMENTS

- 1) Magnetic Separator
- 2) Magnetic DE Stoner
- 3) Drum Type Magnetic Separator
- 4) Magnetic Rod / Tube Magnet
- 5) Drawer Magnet
- 6) Plate Magnet
- 7) Suspension Magnet

VIBRATING EQUIPMENTS

- 1) Circular Vibrating Screen
- 2) Gyro Screen
- 3) Center Shaft Vibrating Screen
- 4) Vibrator Motor
- 5) Vibrator Shifter
- 6) Mechanical Vibrating Screen
- 7) Tumbler Screen

ELECTRO MAGNETIC EQUIPMENTS

- 1) Electro Magnetic Lifter
- 2) Electro Magnetic Vibro Feeder
- 3) Electro Magnetic Drum Separator
- 4) Electro Magnetic OBMS



Pritesh Patel (M.D.) : +91-9428 419 630
+91-9825 011 912

 Plot No. 118, Road No.6, G.I.D.C.,
Kathawada, Ahmedabad - 382430, Gujarat, INDIA.

 info@linuxmagnetics.com

 www.linuxmagnetics.com

A/c. : +91-9898 125 460 / account@linuxmagnetics.com
Sales : +91-9898 642 663 / sales@linuxmagnetics.com
Service : +91-9825 085 008 / service@linuxmagnetics.com